

TOWN OF COOPERSTOWN

Building Permit Application (Addition/Remodeling)

Date: _____ Permit No: _____

Owner: _____ Contractor: _____

Address: _____ Address: _____

City/St/Zip: _____ City/St/Zip: _____

Phone: _____ Cert. No.: _____

Phone/Cell: _____

Description: _____

Type: _____

Size: _____ Height: _____ Sq. Ft.: _____ Value: _____

Work Consists Of:	Inspections Required:	Fees:
New Building _____	Footing _____	Inspections _____
Additions _____	Foundation _____	Permits _____
Remodeling _____	Rough In _____	Fees Paid _____
Electrical _____	Insulation _____	
Plumbing _____	Occupancy _____	
HVAC _____		
Moving _____		

Replacement of existing improvement _____

Agricultural Storage Facilities _____

Commercial buildings _____

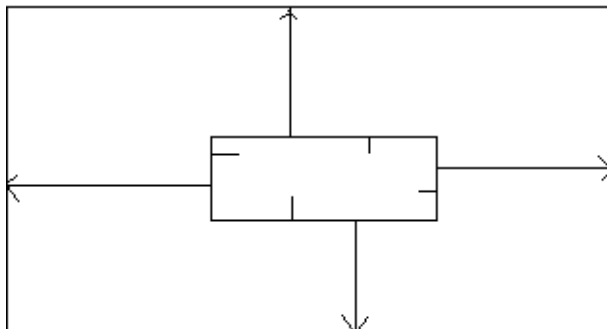

Permission is hereby granted for the above described work on condition that same be done in accordance with the application plan and specification on file, and in compliance with the building ordinance and all other ordinances of the Town of Cooperstown, and the State Building Code of Wisconsin, and that all work (footing, foundation, backfill, structural, rough, and final inspections) be reported when ready for inspection as required by the Building Inspector.

Date Issued _____

Inspectors _____

Signature _____

Owner or Agent _____

Signature _____

REQUIREMENTS FOR OBTAINING A BUILDING PERMIT AND INSPECTION

A: New Construction.

No one-family or two-family dwelling, the initial construction, of which shall commence after the effective date of this ordinance, shall be built, enlarged, altered, or repaired unless a building permit for the work shall first be obtained by the owner, or the owner's agent from the Building Inspector. Applications for a building permit shall be made in writing upon that form designated by the Town and Wisconsin Uniform Dwelling Permit Application, furnished by the Wisconsin Department of Commerce, through the Clerk. There shall be submitted with the application, two (2) complete sets of plans and specifications, showing the location of the proposed building with the respect to adjacent roads, lot lines and buildings. Plans for the buildings required to comply with commercial or industrial building codes shall bear a stamp of approval from the State of Wisconsin. What constitutes a new home? All homes must be treated equally: new construction, manufactured dwellings, manufactured homes (mobile home). Any home placed on a vacant lot is a new home. All new home building must have an enclosed basement with a minimum of 8 ft high walls. Variances can be requested by hearing. All dwellings must conform to all Wisconsin Uniform Dwelling codes for remodeling and new.

B. Addition and Alterations.

No person shall, in excess of \$2500 in cost of material and labor, build, add onto and/or alter any building within the scope of this ordinance without first obtaining a building permit for such work from the Clerk. Any structural changes or major changes shall require permits. Restoration or repair of an installation (re-siding, re-roofing, new windows, replace concrete, electrical or plumbing) to its previous code-complaint condition is exempt from permit requirements.

Before receiving building permits, the owner or his agent must pay into the Town Treasury:

NEW

Initial fee for one-and two-family dwellings \$600 and \$700, respectively, plus \$35 State Seal for total of \$635 and \$735, this includes 7 inspections, additional inspections exceeding 7 will billed at an additional \$75 per trip charge, plus the Town of Cooperstown shall require a non-refundable \$200 fee for any additional costs for building related items: fees for meeting, zoning, inspector's education and clerical fees.

OTHER BUILDINGS New construction of outbuildings, garage, pole buildings that are non-agricultural, non-dwelling or non-commercial require a building permit. The Town will impose a \$65 permit fee for new construction over \$2500 in cost of material and labor, plus inspections as applicable (see below). Permit- min. \$65 fee - for first \$1000 in excess of \$5000. \$1 for each \$1000 will be charged. The maximum fee for remodeling would not exceed \$165. The inspection fee would be additional. Example: cost \$105,000: \$65 for first \$5000 plus \$1 for \$1000 over \$5000 equals \$165, plus inspection fees. Any agricultural buildings are exempt from inspection by the State.

REMODEL

* Construction- min. \$65 fee - for each \$1000 in excess of \$5000. \$1 per \$1000 will be charged. The maximum fee for remodeling would not exceed \$165, the inspection fees would be additional. Example: cost \$105,000: \$65 for first \$5000 plus \$1 for \$1000 over \$5000 equals \$165, plus inspection fees.

* Electrical- min. \$65 fee - for first \$3000, over \$3000 \$1 for each \$100 up to a max of \$100 plus inspection fee \$75 for each inspection. This would include up-grade of service. Example: cost \$4500: \$3000 fee \$65 plus \$15 for \$1500 plus inspection fee \$75= (\$155)

* Plumbing - min. \$65 fee - for first \$3000, over \$3000 \$5 for each fixture unit up to max \$100 plus inspection fee \$75 for each inspection

Example: cost \$3000 and six additional fixtures: \$3000 fee \$65 plus \$30 for fixtures plus inspection fee \$75= (\$170)

* A/C - \$25 fee plus \$75 inspection for receptacle and breaker (change out no fee)

* Outdoor Furnace - \$25 fee, if connected to potable water supply plus inspection (\$75)

* Moving Permit (moving into town)-\$50

* Moving Inspection - \$75.00 per hour fee

The Town will impose a \$50 permit fee for any new or remodeling agricultural structure.

Commercial buildings must meet all State Codes. Building permit fee will be \$200 plus 10% of cost, max \$500. In addition to the established schedule of fees, the building permit fee shall include all costs for inspections and other out-of-pocket costs and expenses incurred by the Town. The applicant shall deposit the fee, including inspection costs, with the Town Treasurer prior to issuance of the building permit. For all other changes not listed, no permit is required below \$2500.

For any further information or questions regarding your permit, you may contact:

Roger Mayer, Certified Building Inspector, 920-726-4583 mobile 920-973-5270

Susan Kornely, Clerk, 920-863-3261

REQUIREMENT FOR OBTAINING A BUILDING PERMIT AND INSPECTION

1. No work shall begin until a Wisconsin Uniform Building Permit has been issued.
2. To obtain a Wisconsin Uniform Building Permit, two (2) sets of complete plans must be submitted for plan approval along with a Wisconsin Uniform Building Permit Application to the Building Inspector.
3. After plans have been reviewed and approved. A Wisconsin Uniform Building Permit will be issued and work may begin subject to the following inspections:
 - A. FOOTING INSPECTION;
 - B. FOUNDATION INSPECTION;
 1. To be inspected after foundation or basement walls are completed and foundation drain tiles are laid before any back filling is done.
 - C. ROUGH IN INSPECTION;
 1. To include rough construction, plumbing rough in, electrical rough in and heating, ventilation and air conditioning rough in.
 2. To be inspected after completion of rough ins and before any plumbing under basement floor is buried and before any insulation is installed.
 - D. INSULATION INSPECTION;
 1. To be inspected after all insulation is completed and before any walls are closed.
 - E. OCCUPANCY OR FINAL INSPECTION;
 1. To be inspected after all work has been completed and before any occupancy. 5 working days.
4. It shall be the responsibility of the contractor to request all required inspections. Further work may not be continued until after the required 48 hours from time of requesting the inspection have lapsed or the inspection has been completed.
5. For any further information or questions regarding your permit, you may contact:
Roger Mayer, Certified Building Inspector, 920-726-4583
Susan Kornely, Clerk, 920-863-3261

EXPIRATION OF BUILDING PERMIT.

One (1) year for remodeling, if not started within one hundred twenty (120) days becomes void; two (2) years for new one-family and two-family, if not started within six (6) months becomes void. Extensions can be requested. Stop work order will be enforced if all codes are not met.